

## Gas Furnace / Boiler Maintenance Agreement

- Check safety controls/operation
- Check and calibrate thermostat
- Replace /clean air filter (filter **not** included)
- Check igniter
- Check high limits
- Check all safety and operating controls
- Check heat exchanger for cracks or leaks where accessible
- Check condensate traps
- Check condensate pumps
- Check exhaust or vent motors
- Check combustion airflow switch
- Check gas valve and operation
- Check efficiency
- Check aquastat, high limits
- Check water feed
- Check circulator, oil if needed

- Check fan blower wheel
- Check temp/pressure gauge
- Check boiler temperature
- Automatic reminders
- Emergency service during normal working hours
- Eligible for **24-hour** service
- **15%** discount on all labor for repairs
- **15%** discount on parts used during a repair
- **5%** discount for HEATING/COOLING customers

**\$109.00** per system

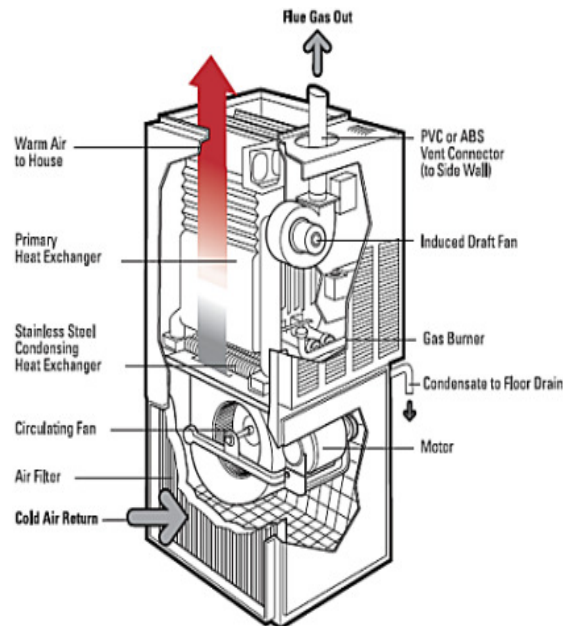

## Other Services we provide

- Add Electronic air cleaner service **\$29.00**  
(parts are **not** included)
- Add flow-thru humidifier service **\$29.00**  
(parts are **not** included)
- Add steam humidifier service **\$45.00**  
(parts are **not** included)
- Add gas-fired hot water heater **\$39.00**  
(parts are **not** included)
- Add electric hot water heater **\$29.00**  
(parts are **not** included)

